

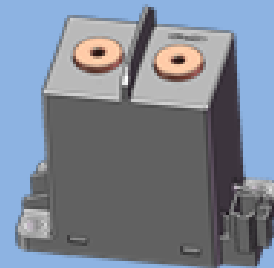

High Voltage DC Contactor

GLFY600B 高压直流接触器



◇ 产品概述 Product Introduction

型号 Type	GLFY600B/1000-XX-HC5
主触点形式 Main Contact Arrangement	一组常开 1 Form A
触点材料 Contact Material	铜合金 Copper Alloy
触点表面处理形式 Contact Surface Treatment Form	无 None
密封类型 Seal Type	陶瓷密封 Ceramic Sealing
外形尺寸 Outline(L×W×H)	95.8mm×49mm×93mm
重量 Unit Weight	660×(1±7%)g

◇ 线圈额定参数 Coil Characteristics

@-40℃~85℃

额定电压 Rated Voltage V DC	工作电压范围 Working Voltage Range V DC	驱动方式 Driving Mode	动作电压 Pick-up Voltage V DC	释放电压 Drop-out Voltage V DC	线圈电阻 Coil Resistance Ω(@23℃)	线圈额定功耗 Coil Rated Power W (@23℃)
12	9~16	单线圈 Single coil	≤9	≥1	18×(1±10%)	约 8 Approx.8
24	18~32	单线圈 Single coil	≤18	≥1	72×(1±10%)	约 8 Approx.8



◇ 触点参数 Contact Characteristics

额定工作电流 Rated Load Current	600A (导线或铜排截面积300mm ²) 600A (wire or busbar cross-section 300mm ²)
最大切断电流 Max. Breaking Current	2000A 1000V DC 1次(op)
工作电压范围 Working Voltage Range	12~1000V DC
最小负载 Min. Applicable Load	1A 12V DC
接触电阻 Contact Resistance	≤0.2mΩ @600A (初始) ≤0.2mΩ @600A (Initial)
电流耐受 (导体截面积300mm ² , 85℃) Current Endurance(Wire 300mm ² , 85℃)	600A 持续 cont. 700A 400s 800A 200s 1000A 70s 2000A 10s

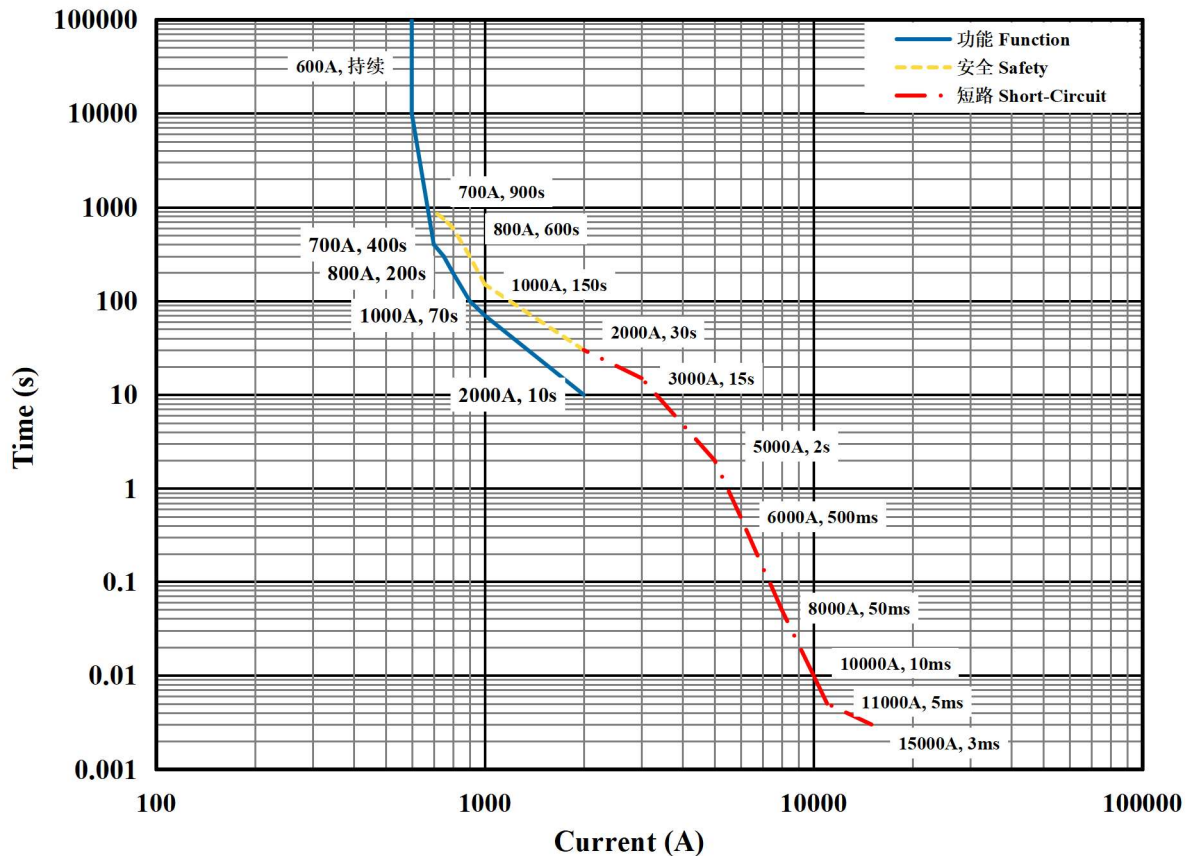

电流耐受曲线
Current Endurance

注 (Notes):

1 环境温度为85℃, 铜排截面积≥300mm²。



The ambient temperature is 85°C, and the cross-section of busbar is $\geq 300\text{mm}^2$.

- 2 设定的功能曲线温度上限为130°C，表示长期循环使用的最大能力；安全曲线温度上限180°C，表示短时过载耐受的最大能力；温度超过180°C时，接触器可能发生功能失效；建议正常工况在功能曲线以下使用。

The upper limit of the function temperature is 130°C, which indicates the maximum capacity of long-term recycling; and the upper limit of the safety temperature is 180°C, which indicates the maximum capacity of short-term overload tolerance. If the temperature exceeds 180°C, the contactor may lose function. It is recommended to use the contactor under the function curve at the normal conditions.

- 3 电流2000A~15000A短时工作时，接触器可能会粘连，但不起火，不爆炸。

When the current is 2000~15000A for short time, the contactor no fire or explosion but may welding.

- 4 电流 $> 12000\text{A}$ 时，接触器触头很可能发生斥开，如果保险丝不能及时熔断，那么接触器可能发生起火、爆炸。

The contactor contacts may be separate when the current is over 12000A, if the fuse does not cut off circuit in time, the contactor may fire or explosion.

- 5 该曲线数据供设计参考，选型及短路匹配保险丝时以实际验证为准。

The data is for design reference, it shall be verified as actual for model selection and fuse mating short-circuit current test.

◇ 耐久性 Endurance

电耐久性（容性） Electrical Endurance(Capacitive)	接通（Making） 200A 20 V DC 75k 次(ops)
电耐久性（阻性） Electrical Endurance(Resistive)	分断（Breaking） 10A 1000V DC 100k 次(ops) 20A 1000V DC 50k 次(ops) 600A 1000V DC 50 次(ops) 2000A 1000V DC 1 次(op)
短路电流 Short Circuit Current	15000A (3ms)不烧、不炸 With no fire or explosion
机械耐久性 Mechanical Endurance	200,000 次(ops)

注(Notes):

- 1 以上数据仅供参考。

The data is for reference only.

- 2 铜排截面积： $\geq 300\text{mm}^2$ 。

The cross-section of busbar: $\geq 300\text{mm}^2$.

- 3 以上数据是在阻性负载（ $L/R \leq 1\text{ms}$ ）条件下测得，负载通断比：0.6s:5.4s，环境温度：23°C；以上数值会因负载类型、通断频率、环境条件等条件变化而发生改变，因此在使用时，推荐在实际负载下进行确认。

The data is measured under the resistive load ($L/R \leq 1\text{ms}$), the ratio: 0.6s on:5.4s off, ambient temperature: 23 °C; The values may change according to the load type, ratio, and environmental conditions. Therefore, it is recommended to confirm the values under actual load.



◇ 性能参数 Performance

绝缘电阻（断开主触点间） Insulation Resistance（Open between main contacts）	试验前Before Test $\geq 1000\text{M}\Omega$ (at 1000V DC) 试验后After Test $\geq 10\text{M}\Omega$ (at 1000V DC)
绝缘电阻（主触点与线圈间） Insulation Resistance（Between main contact and coil）	试验前Before Test $\geq 1000\text{M}\Omega$ (at 1000V DC) 试验后After Test $\geq 10\text{M}\Omega$ (at 1000V DC)
介质耐压(断开触点间,漏电流 $\leq 1\text{mA}$) Dielectric Strength (Open,between main contacts, leak current $\leq 1\text{mA}$)	试验前Before Test $\geq 3000\text{V AC}$ (50/60 Hz 1min) 试验后After Test $\geq 2250\text{V AC}$ (50/60 Hz 1min)
介质耐压(触点与线圈间,漏电流 $\leq 1\text{mA}$) Dielectric Strength(Between contacts and coil, leak current $\leq 1\text{mA}$)	试验前Before Test $\geq 3000\text{V AC}$ (50/60 Hz 1min) 试验后After Test $\geq 2250\text{V AC}$ (50/60 Hz 1min)
吸合时间（线圈额定电压下，23℃） Pick-up Time (At rated coil voltage, 23℃)	$\leq 50\text{ms}$
释放时间（线圈额定电压下，23℃） Release Time (At rated coil voltage, 23℃)	$\leq 30\text{ms}$
吸合回跳时间（线圈额定电压下，23℃） Operate Bounce Time (At rated coil voltage, 23℃)	$\leq 10\text{ms}$
正弦振动 Sine Vibration	10Hz~500Hz, 49m/s ²
耐冲击-断开状态下误动作冲击 Shock – Functional Open	半正弦波, 11ms, 98m/s ² 1/2 sine, 11ms, 98m/s ²
耐冲击-闭合状态下误动作冲击 Shock–Functional Close	半正弦波, 6ms, 490m/s ² 1/2 sine, 6ms, 490m/s ²
耐冲击-强度冲击 Shock - Destructive	半正弦波, 6ms, 490m/s ² 1/2 sine, 6ms, 490m/s ²
随机振动 Random Vibration	10Hz~2000Hz, 57.9m/s ²



◇ 标准测试条件 Standard Test Condition

温度 Temperature	23°C±5°C
湿度 Humidity	25%~75%RH
方向 Direction of Test	立式 Vertical

◇ 使用条件 Operating Condition

触点允许的最高温度(长时) Maximum allowable temperature of contacts(Long-time)	130°C
触点允许的最高温度(短时) Maximum allowable temperature of contacts(Short-time)	180°C
温度 Temperature	-40°C~+85°C
湿度 Humidity	5%~95%RH
海拔 Altitude	≤4000m
安装方向 Mounting Direction	立式 Vertical

◇ 贮存条件 Storage Condition

温度 Temperature	10°C~75°C
湿度 Humidity	5%~85%RH



◇ 产品命名规则 Product Code Structure

	GLFY600B	/1000	— XX	—H	C	5		—XXX	X
产品型号 Product Type									
负载电压 Contact Voltage	1000:1000V								
线圈电压 Coil Norminal Voltage	12:12V DC 24:24V DC								
触点型式 Contact Arrangement	H: 1组常开型 H: 1 Form A								
线圈引出形式 Coil Terminal	C:连接器 Connector								
负载引出形式 Load Terminal	5:内螺纹 Female Thread								
产品安装形式 Product Installation Form	无 none:立式安装 Vertical install								
客户代码 Customer Code	客户需求（当客户存在特殊需求时使用） Customer requirement(Only for special requirements)								
特性代码 Feature Code	产品特性（同型号产品不同特性要求时使用） Product characteristics (Only for different characteristics of the same product type)								



◇ 外形图 Outline Dimensions

产品型号 Product Type: GLFY600B/1000-XX-HC5

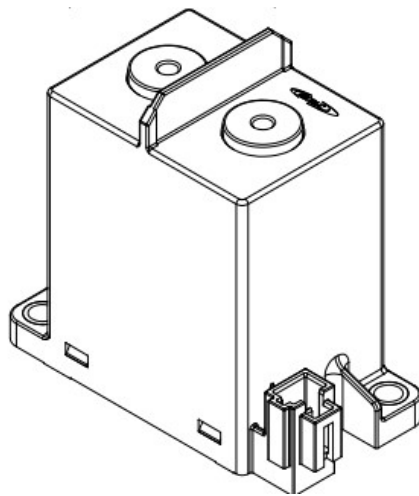
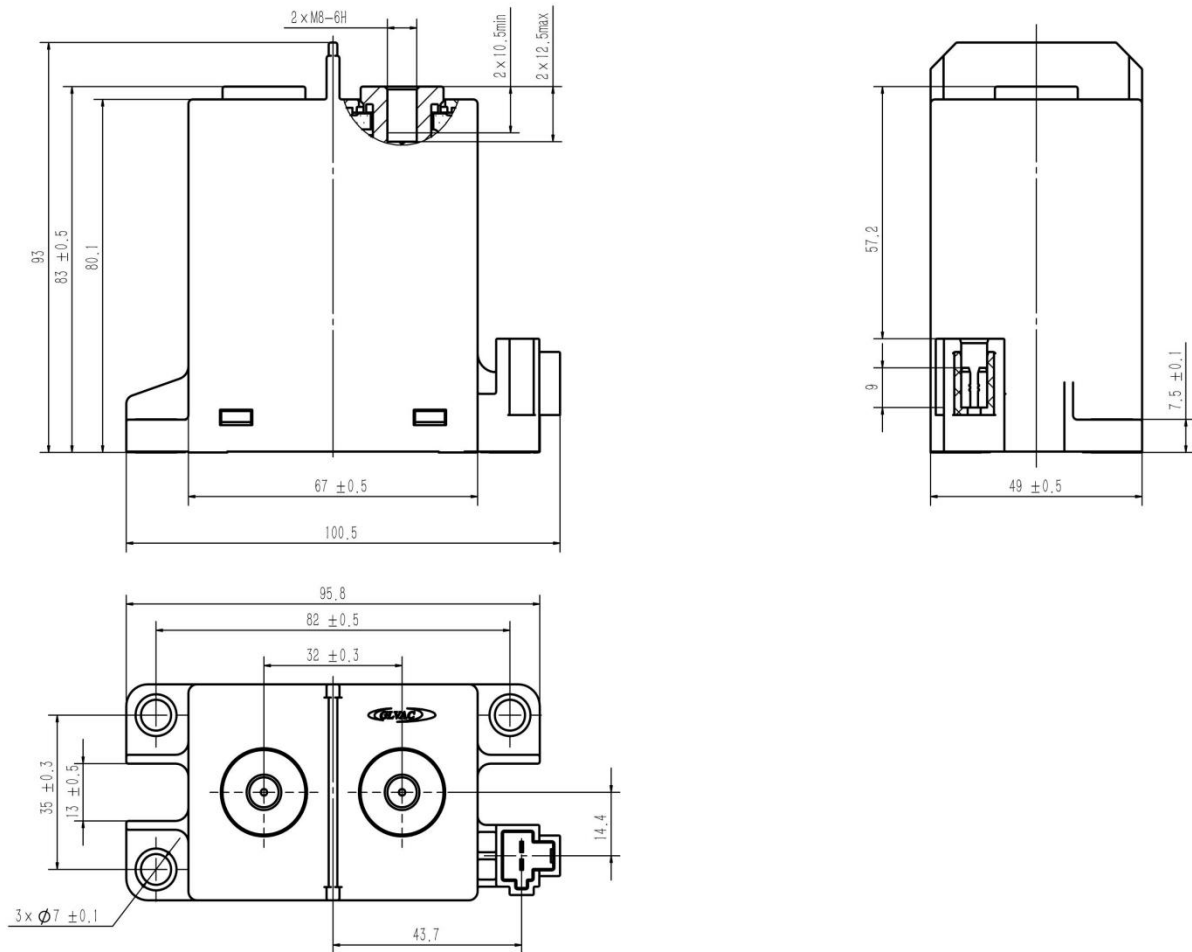



◇ 接线图 Circuit Diagram

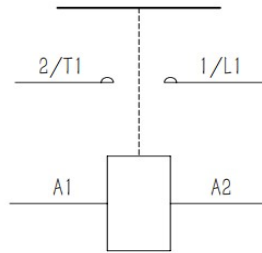

负载无极性，线圈无极性
The load is non-polarity, the coil is non-polarity

注(Notes):

1 所有尺寸单位为mm。

All dimensions are in mm

2 产品外形尺寸未注公差:

All unspecified tolerance according to the table as below:

尺寸 Dimension(mm)	<10	10~50	>50
公差 Tolerance(mm)	±0.3	±0.5	±0.8

3 产品适配的连接器的，具体型号如下:

The contactor specified connector, details as follows:

品牌 Brand	护套 Connector Housing	插针 Crimp Terminal
矢崎 Yazaki	7283-1020	7116-4020
天海 THB	0435308	01175

天海 THB: 0435308 或矢崎: 7283-1020

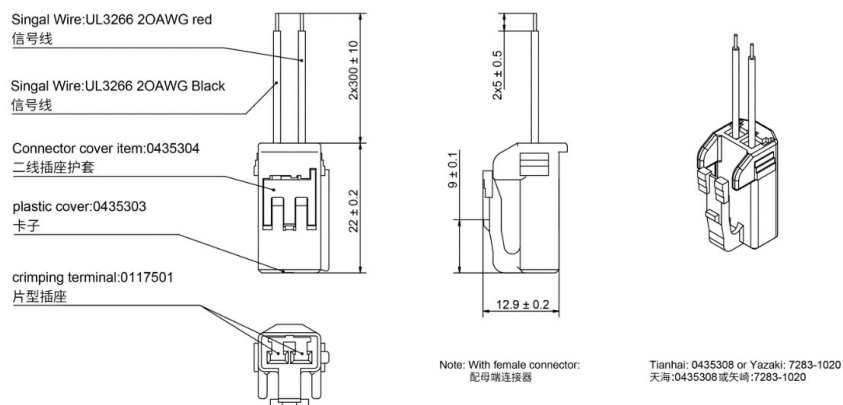



◇ 应用信息 Application Notes

- 1 出货信息：产品默认出货不含连接器线束、螺钉、垫片、弹垫等安装配件。

Shipping information: The delivery product is shipped without connector harness, screws, washers, spring washers and other installation accessories.

- 2 当接触器使用1个及多个导电铜排连接时,请确保导电铜排与触点端面紧密贴合(多个铜排需确保大电流的导电铜排最贴近触点端面,小电流的导电铜排其次),然后是平垫圈、弹簧垫圈、螺钉。不正确的连接顺序可能造成严重过热。

When contactor is connected with one or more busbars, please ensure that the busbars are tightly attached to the end faces of the contacts (when there are multiple busbars, please ensure that the busbar with large current is next to the contact terminal face, and the busbars with low current come next), then the flat washer, spring washer and screw. Incorrect connection order can cause severe overheating.

产品类型 Contact Type	连接示意图 Connection Diagram
内螺纹型 Internal Thread	

- 3 安装时请避免附着异物、油脂类及腐蚀性液体,否则会导致接触器触点端发热异常。

During installation, please avoid attaching foreign objects, grease and corrosive liquids, otherwise it will cause abnormal heating at the contact end of the contactor.

- 4 请在强磁界(变压器、磁铁的周围)和发热物体的附近安装。

The contactor should not be installed near strong magnetic fields (transformers, magnets around) and should not be installed near heat source.

- 5 接触器安装的锁紧力矩请控制在下表规定范围内,超过范围可能导致螺纹损坏。

The tightening torque of the contactor installation is recommended as the table below. Exceeding the range may cause thread damage.

负载端安装部分 Fixing of Contact					
安装方式 Installation Type	扭矩要求 Torque	破坏扭矩 Destructive Torque	建议铜排厚度 Recommended Copper Bar Thickness	建议铜排平面度 (安装面) Recommended Copper Bus Flatness (Mounting Surface)	建议铜排孔径 Recommended Copper Bar Aperture
M8 螺钉 M8 screw	8Nm~10Nm	≥18Nm	≤5mm	0.1	Φ8.1mm~Φ8.5mm



本体安装部分 Installation at flange side		
安装方式 Installation Type	扭矩要求 Torque	破坏扭矩 Destructive Torque
M6 螺钉 M6 screw	6Nm~8Nm	≥10Nm

6 线圈在断电时，线圈两端会产生反向电动势，此反向电动势会对控制端的MOSFET等器件产生冲击，因此控制电路需在接触器线圈端并联抑制器件来抑制反向电动势。

A reverse voltage occurs when the coil power off, this reverse voltage will have negative impact on control circuit electrical device like MOSFET. A suppression device should be connected in parallel with the coil end of the contactor as a measure to suppress the reverse voltage.

注意事项 (Notes):

6.1 推荐使用钳位电压为线圈额定电压 2 倍以上的双向 TVS 管、压敏电阻、二极管+单向 TVS 管等措施进行反向电动势的抑制。反向电动势抑制器件的钳位电压要低于被保护的 MOSFET 的 VDS 值；
It is recommended to use bi-direction TVS, Varistor (ZNR), Diode plus the unilateral TVS etc. whose clamping voltage is more than 2 times the rated voltage of the coil to suppress the reverse overvoltage of the coil. And the clamping voltage of reverse voltage suppression device should lower than VDS of protected MOSFET.

6.2 TVS 管及压敏电阻的能量吸收能力至少在 1J 以上；

TVS and ZNR the max energy absorption capability: ≥1J

6.3 禁止用续流二极管 Diode 进行反向电动势的抑制，这样会延长接触器负载端释放时间，导致产品切断性能下降。

Please do not use freewheel diode, it will make the release time of contactor increase, which will lead to contactor cutting-off performance reduced.

7 接触器应用在容性负载回路时，请注意采取预充等措施，建议接触器闭合压差控制在20V以内。如未采取措施，可能会造成触点粘连。

When the contactor is used in a capacitive load circuit, please pay attention to pre-charge and other measures. It is recommended that the contactor closing voltage difference be controlled within 20V. If no measures are taken, the contacts may welded.

8 接触器应用在感性负载回路时，建议对感性负载并联加装浪涌吸收措施。如未采取措施，可能导致接触器切断能力有所下降。

When the contactor is used in the inductive load circuit, it is recommended to install surge absorption measures in parallel to the inductive load. If no measures are taken, the contactor's cutting capability may be reduced.

9 接触器的内部触点使用了气体保护，伴随着触点温度变化(环境温度+通电致使温度上升)而存在内部气体穿透，严禁将继电器长时间置于超过产品温度使用范围(-40°C~85°C)环境中。

The contactor contacts are encapsulated in protection gas atmosphere, internal gas penetration with



contact temperature changes (ambient temperature + electricity causes temperature rise). So please avoid using or storing beyond the allowable temperature range $-40^{\circ}\text{C}\sim 85^{\circ}\text{C}$ for long time.

- 10 请避免接触器在使用或运输过程中发生撞击或跌落。为保持接触器的性能，撞击或跌落后的接触器不建议继续使用。

Please avoid impact or drop of the contactor during application or transportation. In order to maintain the performance of the contactor, it is not recommended to continue to use the contactor after impact or fall.

- 11 产品完全符合RoHS2.0要求，对环境更友好。

Products meet RoHS2.0 and environment friendly.

- 12 接触器在规定条件下存储时间为1年，超过1年不建议使用。

The storage time of contactors is 1 years under the specified storage conditions, storage over 1 years is not recommended to use.

- 13 如需获取更多信息与支持，请联系昆山国力源通新能源科技有限公司。

Please contact GuoLi YuanTong for more information or support.

声明：

Statements:

本资料仅供客户参考，源通尽力确保本资料中信息的准确性，但产品规格参数可能因为产品改良等发生变更，具体涉及的每个产品的参数及性能请以源通提供的规格书和样品为准。如有需求，请与我司联系以提供最新的产品规格书。

关于应用领域，我们无法评估接触器在每个具体应用领域的所有性能和参数，请客户根据具体的使用条件选择适用的产品。若有疑问，请与源通联系以便获取更多的技术支持。源通明确声明本资料中的信息仅供选型参考，且产品选型责任仅由客户负责。

This information is for customer reference only. Yuan Tong endeavors to ensure the accuracy of the information in this data, but the product specifications and parameters may be changed due to product improvement, etc. For the specific parameters and performance of each product, please refer to the specifications and samples provided by Yuan Tong. If required, please contact us to provide the latest product datasheet.

Regarding the application field, we can not evaluate all the performance and parameters of the contactor in each specific application field, please select the appropriate product according to the specific application. If there is a demand, please contact Yuan Tong for additional technical support. Yuan Tong expressly states that the information in this material is for selection reference only, and the product selection is the responsibility of the customer only.